



**BUILT
FOR THE FUTURE**

AWWA D110 Type III

PRESTRESSED CONCRETE TANKS



DURABILITY FOR GENERATIONS TO COME

For more than 90 years, DN Tanks has constructed liquid storage tanks to provide you with a reliable water source when you want it, and more importantly, when you need it. It is not just our passion; it's our legacy.

We are a solutions-focused company and back our tanks with employees who are committed from inception through construction and beyond to give you the best solution for your system.

When considering your community's potable water source, fire suppression system, thermal energy storage, wastewater and recycled water containment and all your system storage needs, think of DN Tanks.

4 Site Preparation

5 Floor Construction

6 Precasting Wall & Dome Panels

8 Erecting Wall & Dome Panels

10 Tank Closure

12 External Wire Prestressing

14 Completing the Tank

15 Interior Piping, Appurtenances & Water Quality

16 Tank Rendering

18 DN Tanks Showcase



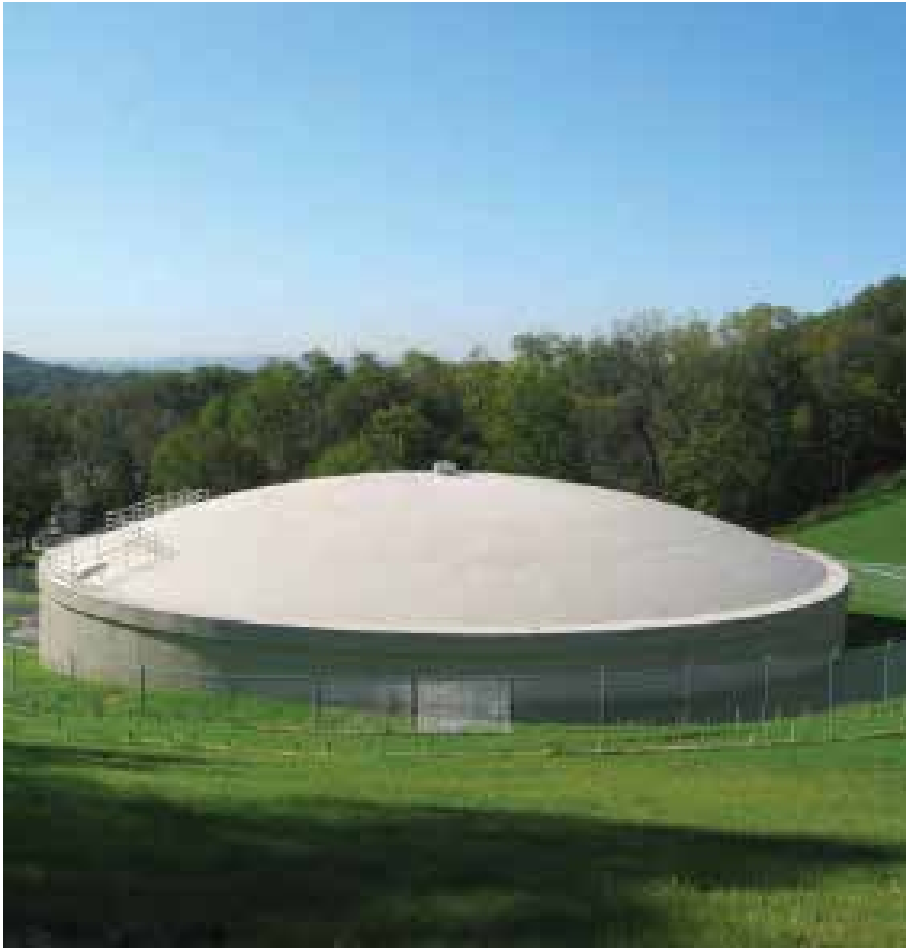

Key Attributes of a DN Tanks AWWA D110 Type III Prestressed Concrete Tank

- Tank Capacities — from 40,000 gallons to 50 million gallons (MG) and more.
- Custom Dimensions — water heights from 8' to over 100' and diameters over 500'.
- Siting Options — at grade, partially buried, differentially back-filled (hillsides) and fully buried (with multi-use capabilities).
- Seismic Resilience — designed with an anchored flexible base for enhanced ductility and seismic performance.
- Durability — regardless of weather extremes, proven reliability through extreme fire and freeze thaw events.
- Prestressed Wall Compression — provides longevity, durability and liquid tightness.
- Reinvesting in the Local Economy — use of materials, labor and equipment from within the community.
- Enhanced Water Quality — concrete inherently insulates, keeping liquids at a more consistent temperature.
- Best Long-term Value — our tanks speak for themselves. No coatings required, which eliminates routine maintenance costs and downtime. Request a lifecycle cost analysis today.



SITE PREPARATION

Site work and foundation preparation are in accordance with the site plan and the geotechnical report prepared by a licensed geotechnical engineer, which provides the bearing capacity, anticipated settlements and recommended foundation preparation.

- Site clearing and general excavation are undertaken in preparation for tank construction.
- The exposed subgrade is proof-rolled and tested for conformance with the geotechnical report. Select granular fill is placed, if required, for drainage or where unsuitable material is present. The leveling base granular material is then put down in layers and compacted to meet foundation requirements.
- Site preparation includes creating an access roadway around the tank at floor elevation as well as level areas adjacent to the tank for wall and dome casting beds. The casting beds are located near the tank to allow the wall and dome panels to be erected into place.



Subgrade preparation for each project is customized based on local soil conditions.

FLOOR CONSTRUCTION

A standard DN Tanks floor is monolithically cast with a reinforced concrete membrane floor designed to transmit the load of the stored liquid to the soil foundation. When required by tank configuration or site conditions, DN Tanks utilizes soil improvements, deep foundation systems or a structural floor slab.

- Footing forms are constructed around the tank perimeter. A PVC waterstop is vertically suspended for partial encasement in the slab.
- Reinforcing steel and base restraint cables are installed in the floor and footing.
- Concrete is now ready to be placed in the floor where it is vibrated, screeded, and given a freso float finish.
- The floor is then flooded to promote a long, thorough concrete cure, resulting in a high-quality, watertight DN Tanks floor.

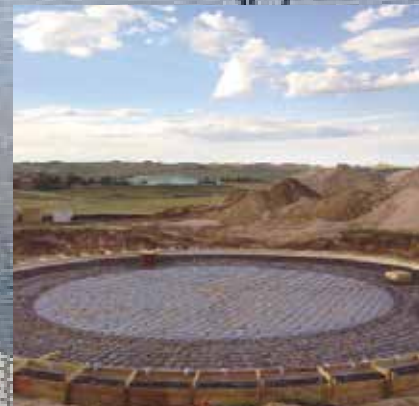



PRECASTING WALL & DOME PANELS

On-site precasting combines in-plant quality with on-site efficiency.

- Wall and dome panels are precast on-site in casting beds that are custom formed to the curvature of each tank.
- An essential feature of AWWA D110 Type III tanks is the use of an embedded steel diaphragm in the tank wall, which acts as a positive water barrier to assure watertightness.
- The standard DN Tanks Type III roof system utilizes a freestanding, spherical, concrete dome with no interior columns.
- The dome is constructed as a series of concentric rows of individual dome panels, curved radially and circumferentially to form a spherical dome.
- When required due to site conditions, DN Tanks can construct a cast-in-place dome.
- When a tank is designed to receive earth cover or to minimize the total finished height, DN Tanks constructs a column-supported flat slab concrete roof.





ERECTING WALL & DOME PANELS



► **Precast wall and dome panels are inspected, and concrete quality and strength are confirmed prior to erection.**

- When the floor achieves its required strength, heavy-duty shoring is erected to temporarily support the precast dome panels.
- The wall panels and dome panels are erected concurrently.
- The wall panels are placed onto bearing pads outside of the encased waterstop. Set approximately 7 to 10 inches apart, the wall panels form a series of open slots, which are later closed.
- Simultaneously, the dome panels are set, spanning between the concentric rows of circumferential forms.
- For tanks requiring a flat slab roof, support columns are constructed and a shoring system is erected. Once the roof slab reinforcing is completed, the roof concrete is placed, finished, and cured in place.

TANK CLOSURE

The completed system provides a permanent watertight connection, minimizes vertical bending stresses, and creates resistance to lateral displacement forces.

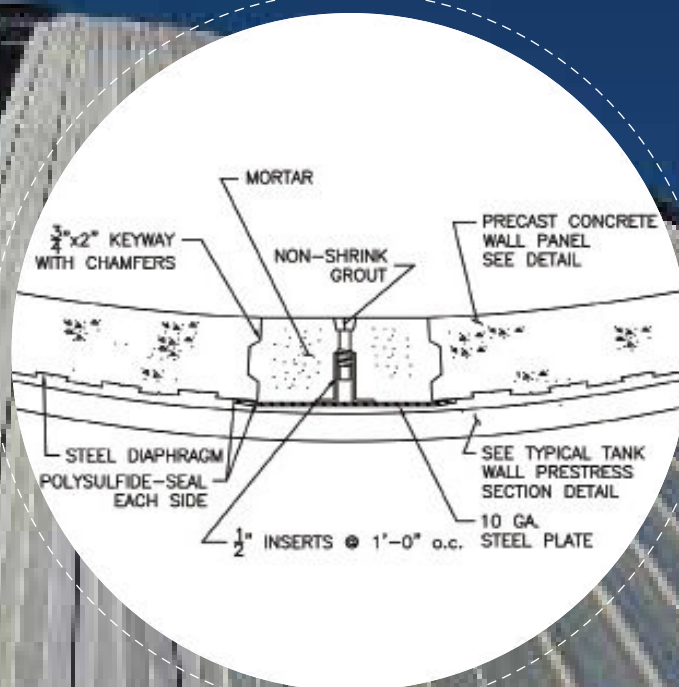

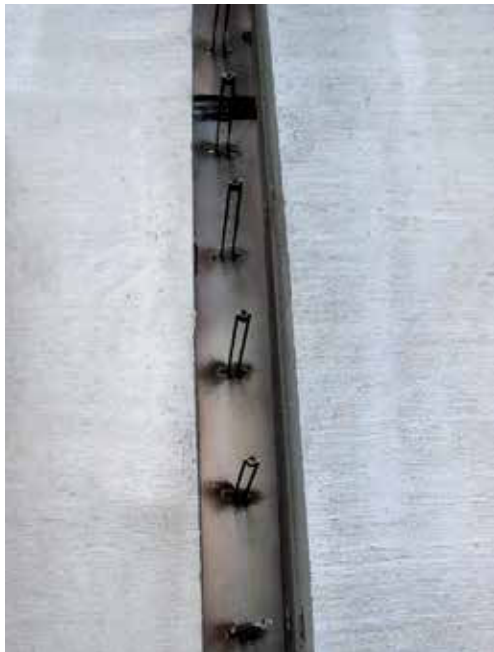

Wall and dome slots are permanently sealed.

- Heavy-gauge steel plates are erected to span the outside of the wall joint. Temporary forms are erected to span the interior joints, and then high-strength, superplasticized mortar is placed to fill the connection.
- The tank wall is now a continuous cylinder consisting of a high-strength, corrosion-resistant concrete wall on the interior surrounded by a watertight steel shell on the exterior.
- The circumferential and radial joints in the dome are reinforced and filled with concrete, producing a uniform spherical shell.

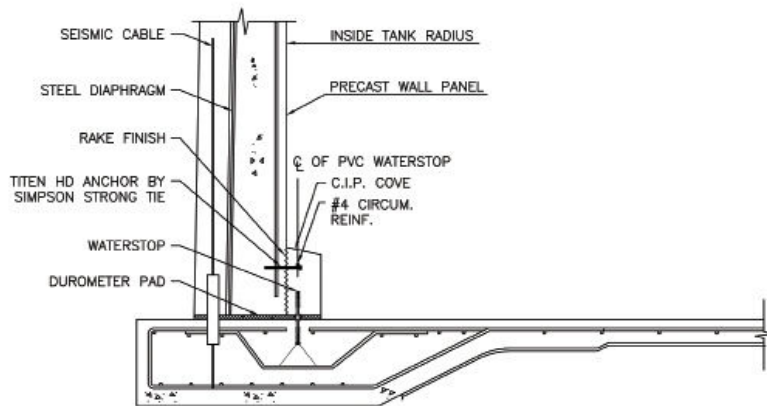
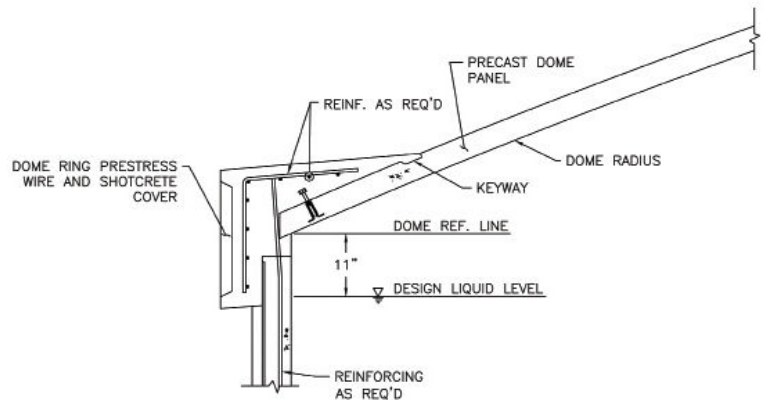

Floor/wall and wall/dome connections are completed.

- The flexible floor/wall connection is designed specifically to minimize vertical bending stresses in the tank wall.
- The waterstop is encased with concrete placed on rubber pads to maintain separation from the floor. The concrete bonds to the rake finish at the bottom of the wall panel.
- A dome ring is formed, reinforced, and cast, providing structural continuity between the tank wall and dome roof.

EXTERNAL WIRE PRESTRESSING

A DN Tanks standard Type III prestressing system utilizes a proven wire-winding method. Multiple layers of high-strength, bright steel prestress wires are applied continuously to gradually place the wall and dome into permanent compression.



An initial layer of shotcrete is applied to the wall, encasing the steel diaphragm and base-restraint cables. The high-pH shotcrete passivates the steel, providing permanent corrosion protection.



→ The redundancy of the multi-layered prestressing provides greater safety for the structure. The number of wire layers and wire spacing are determined by the design requirements. The total prestressing requirements are determined for each tank to provide initial and residual compression.

- A wire spacing device precisely places the wire on the tank wall.
- Reels of wire are spliced together to create continuous prestressing from top to bottom.
- The wire force is measured in place to verify it is within specified tolerances.
- Prestressing for the dome is applied to the vertical face of the dome ring, placing the dome into compression. This results in a freestanding, clear span dome roof.
- Each layer of wire is individually encased and permanently bonded in shotcrete.



COMPLETING THE TANK

After the wire-winding process is completed, a final protective shotcrete covercoat is applied.

- Temporary vertical guide wires are placed two feet on center on the tank wall.
- An experienced DN Tanks nozzle-man then applies the shotcrete cover coat.
- The finished tank exterior receives an architectural concrete coating, providing a uniform tank appearance.
- The tank is tested, chlorinated, and placed in service to provide decades of trouble-free water storage.



In response to specific water quality design requirements, various mixing systems are available, ranging from separated piping, to flow-based systems, to mechanical mixing equipment.

INTERIOR PIPING, APPURTENANCES & WATER QUALITY

- Appurtenances, such as roof and wall access hatches, interior and exterior ladders, vents, safety railings, level sensing equipment or specialized security hardware, are available to meet specific project requirements.
- Baffle wall systems are available to meet C/T design requirements for finished water storage.



- 1 PVC Waterstop
- 2 Duometer Pad
- 3 Steel Diaphragm
- 4 Seismic/Base Restraint Cables
- 5 Layers of Prestressed Wire
- 6 Shotcrete Encasement Over Each Prestressed Layer
- 7 Prestressed Dome Ring
- 8 Free-standing Dome Roof
- 9 Vent



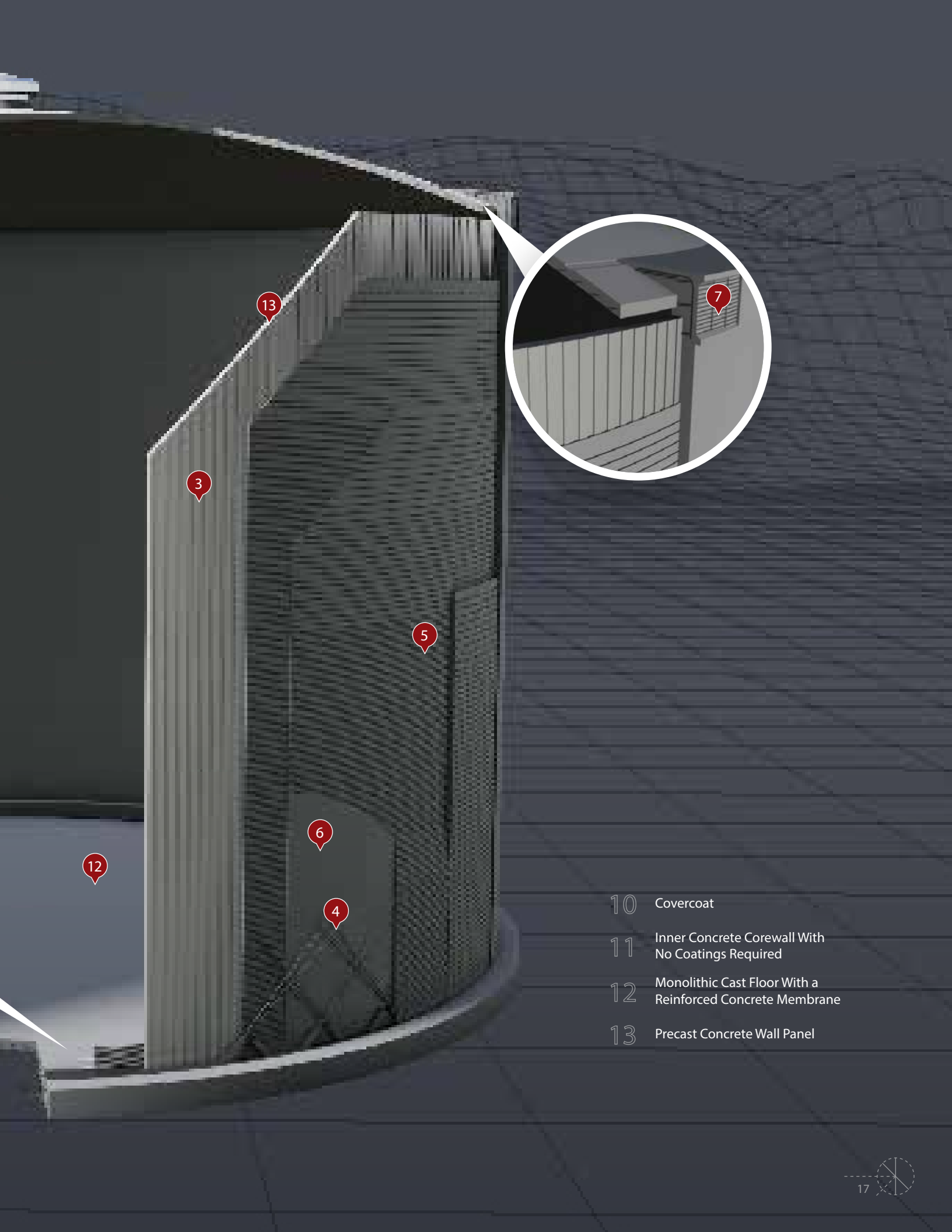

12

3

13

5

6

4



7

- 10 Covercoat
- 11 Inner Concrete Corewall With No Coatings Required
- 12 Monolithic Cast Floor With a Reinforced Concrete Membrane
- 13 Precast Concrete Wall Panel

DN TANKS SHOWCASE



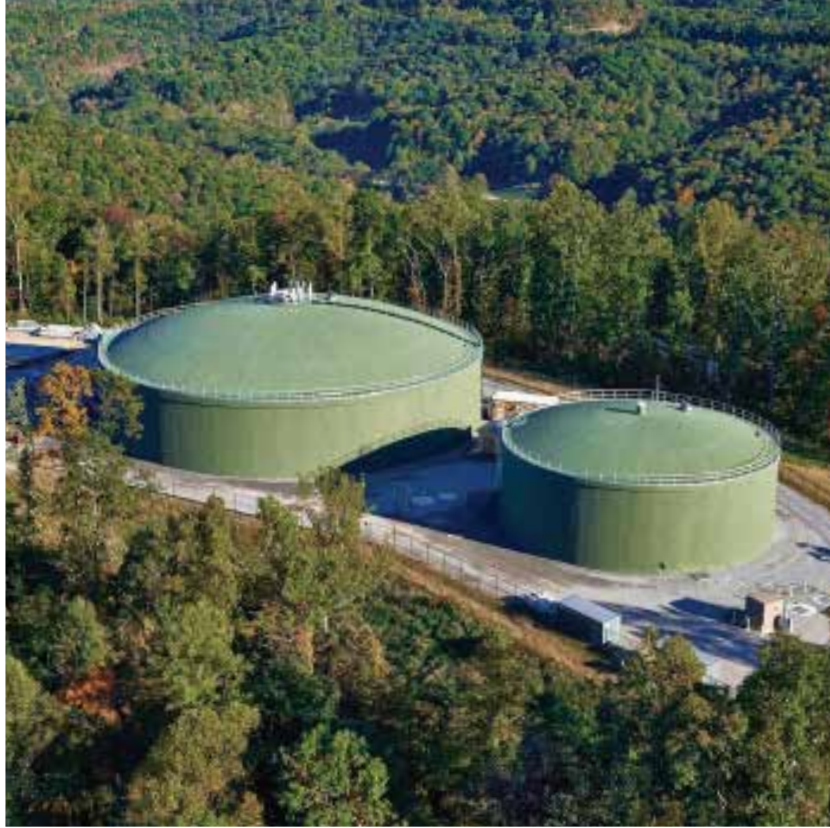



855.368.2657 | DNTANKS.COM

DN Tanks has 10 regional offices and 3 operations facilities located in Greater Boston, MA • Dallas, TX • San Diego, CA

July 2019. © 2019 DN Tanks. All rights reserved. DN Tanks is a registered trademark of DN Tanks.

BUILT
FOR THE FUTURE

